

QFP

QUAD FLAT PACKAGE

Applicable IC/QFP • TQFP • MQFP • CQFP CLAM SHELL TYPE SOCKET

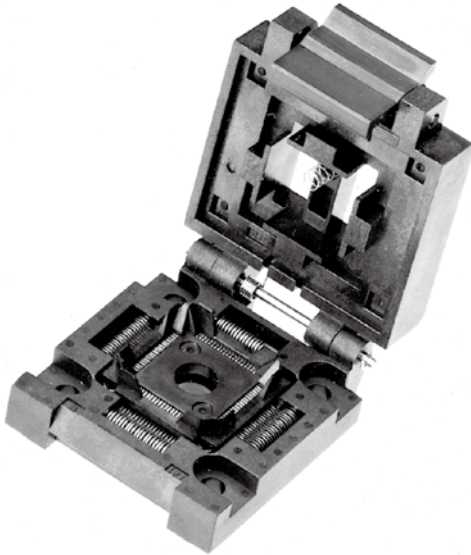

ORDERING PROCEDURE

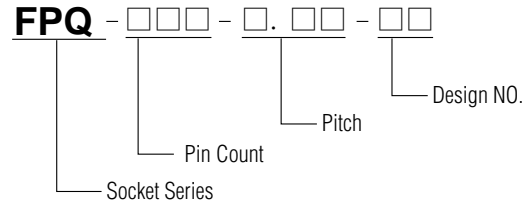

SPECIFICATIONS

- Contact resistance: Initial 30mΩ (At 10 mA)
- Maximum voltage: AC700V RMS (for 1 minute)
(Below 0.5mm Pitch)
AC500V RMS (for 1 minute)
- Insulation resistance: 1,000MΩ or higher (At DC 500V)
- Rated current: 1A
- Operating temperature range: -65°C~+150°C
- Terminal strength against pulling: 0.5kg (1 min)
- Insertion: Min. 10,000 times (mechanical)

MATERIAL

- Body: PPS or PEI, PES
- Contact: BeCu, Au plating (Ni-base)

※RoHS compliant

APPLICABLE IC DIMENSIONS

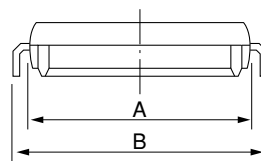
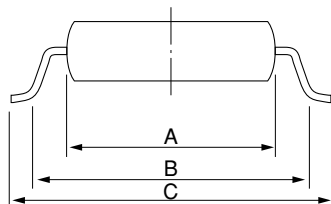

APPLICABLE IC DIMENSIONS

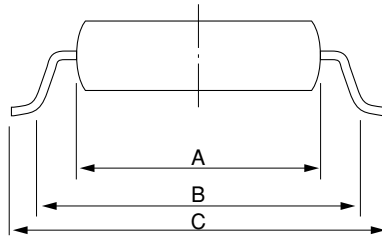

Unit: mm (in.)

PART NO.	PIN COUNT	PITCH	APPLICABLE IC DIMENSIONS (REF.)			REMARKS
			A	B	C	
FPQ-32-0.65-01	32	0.65 (26mil)	7×7 (0.275×0.275)	8.2×8.2 (0.322×0.322)	9×9 (0.354×0.354)	
FPQ-36-0.8-01	36	0.8 (32mil)	10×7 (0.393×0.275)	11×8 (0.433×0.314)	12×9 (0.472×0.359)	
FPQ-44-0.8-06T	44	0.8 (32mil)	10×10 (0.393×0.393)	11.44×11.44 (0.450×0.450)	12.6×12.6 (0.496×0.496)	
FPQ-44-0.8-06B	44	0.8 (32mil)				
FPQ-44-0.8-17	44	0.8 (32mil)	10×10 (0.393×0.393)	11.24×11.24 (0.442×0.442)	22.4×12.4 (0.488×0.488)	
FPQ-48-0.65-02	48	0.65 (26mil)	10×10 (0.393×0.393)	11.1×11.1 (0.437×0.437)	12.2×12.2 (0.480×0.480)	
FPQ-48-0.8-01	48	0.8 (32mil)	10×10 (0.393×0.393)	12.1×12.1 (0.476×0.476)	13.1×13.1 (0.515×0.515)	
FPQ-48-0.8-06	48	0.8 (32mil)	12×12 (0.472×0.472)	13×13 (0.511×0.511)	14.5×14.5 (0.570×0.570)	
FPQ-48-0.8-05	48	0.8 (32mil)	12×12 (0.472×0.472)	14.2×14.2 (0.559×0.559)	15.3×15.3 (0.602×0.602)	
FPQ-56-0.65-01	56	0.65 (26mil)	9.5×10.5 (0.374×0.413)	11.1×12.1 (0.437×0.476)	13.5×14.5 (0.531×0.570)	
FPQ-60-1.0-01	60	1.0 (39mil)	20×14 (0.787×0.551)	22×18 (0.866×0.708)	24×22 (0.944×0.787)	
FPQ-64-0.65-02	64	0.65 (26mil)	12×12 (0.472×0.472)	13.6×13.6 (0.535×0.535)	14.6×14.6 (0.574×0.574)	
FPQ-64-0.8-09A	64	0.8 (32mil)	14×14 (0.551×0.551)	15.6×15.6 (0.614×0.614)	16.6×16.6 (0.653×0.653)	Short Lead
FPQ-64-0.8-10A	64	0.8 (32mil)	14×14 (0.551×0.551)	15.6×15.6 (0.614×0.614)	17.2×17.26 (0.677×0.677)	
FPQ-64-1.0-08A	64	1.0 (39mil)	20×14 (0.787×0.551)	23×17 (0.905×0.905)	25.5×19.6 (1.007×0.771)	
FPQ-80-0.65-01A	80	0.65 (26mil)	14×14 (0.551×0.551)	16.2×16.2 (0.637×0.637)	17.2×17.2 (0.677×0.677)	
FPQ-80-0.65-05A	80	0.65 (26mil)	14×14 (0.551×0.551)	14.8×14.8 (0.582×0.582)	15.6×15.6 (0.614×0.614)	
FPQ-80-0.8-11A	80	0.8 (32mil)	20×14 (0.787×0.551)	22.4×16.4 (0.881×0.654)	24.8×18.8 (0.976×0.740)	

Applicable IC/QFP • TQFP • MQFP • CQFP

CLAM SHELL TYPE SOCKET

METRIC QFP STANDARD

Unit: mm (in.)

PART NO.	PIN COUNT	PITCH	APPLICABLE IC DIMENSIONS (REF.)			REMARKS
			A	B	C	
FPQ-44-0.8-16A	44	0.8 (32mil)	10×10 (0.393×0.393)	12×12 (0.474×0.474)	13.2×13.2 (0.519×0.519)	Short Lead
FPQ-44-0.8-14A	44	0.8 (32mil)	10×10 (0.393×0.393)	12.5×12.5 (0.492×0.492)	14.2×14.2 (0.599×0.599)	Long Lead
FPQ-44-0.8-14C	44	0.8 (32mil)	10×10 (0.393×0.393)	12.8×12.8 (0.503×0.503)	13.9×13.9 (0.547×0.547)	Long Lead
FPQ-52-0.65-02A	52	0.65 (26mil)	10×10 (0.393×0.393)	11.6×11.6 (0.456×0.456)	13.2×13.2 (0.519×0.519)	Short Lead
FPQ-52-0.65-01A	52	0.65 (26mil)	10×10 (0.393×0.393)	12.3×12.3 (0.484×0.484)	13.9×13.9 (0.547×0.547)	Long Lead
FPQ-52-0.65-04	52	0.65 (26mil)	10×10 (0.393×0.393)	11×11 (0.433×0.433)	12×12 (0.472×0.472)	
FPQ-64-0.8-13	64	0.8 (32mil)	14×14 (0.551×0.551)	15.6×15.6 (0.614×0.614)	17.2×17.2 (0.677×0.677)	Short Lead
FPQ-64-0.8-07	64	0.8 (32mil)	14×14 (0.551×0.551)	16.6×16.6 (0.653×0.653)	20×20 (0.787×0.787)	Long Lead
FPQ-80-0.65-02A	80	0.65 (26mil)	14×14 (0.551×0.551)	15.6×15.6 (0.614×0.614)	17.2×17.2 (0.677×0.677)	Short Lead
FPQ-80-0.8-12A	80	0.8 (32mil)	14×20 (0.551×0.787)	15.6×15.6 (0.614×0.614)	17.2×23.2 (0.677×0.913)	Short Lead
FPQ-80-0.8-13A	80	0.8 (32mil)	14×20 (0.551×0.787)	16.2×22.2 (0.637×0.874)	19.6×25.6 (0.771×1.007)	Long Lead
FPQ-100-0.65-16A	100	0.65 (26mil)	14×20 (0.551×0.787)	15.8×21.8 (0.622×0.858)	17.2×23.2 (0.677×0.913)	Short Lead
FPQ-100-0.65-11A	100	0.65 (26mil)	14×20 (0.551×0.787)	16.2×22.2 (0.637×0.874)	17.6×23.6 (0.693×0.929)	Long Lead
FPQ-120-0.8-03A	120	0.8 (32mil)	28×28 (1.102×1.102)	30.8×30.8 (1.212×1.212)	31.9×31.9 (1.256×1.256)	Long Lead
FPQ-120-0.8-04A	120	0.8 (32mil)	28×28 (1.102×1.102)	30.3×30.3 (1.193×1.193)	31.2×31.2 (1.228×1.228)	Short Lead
FPQ-128-0.8-04A	128	0.8 (32mil)	28×28 (1.102×1.102)	30.4×30.4 (1.197×1.197)	31.2×31.2 (1.228×1.228)	Short Lead
FPQ-128-0.8-03	128	0.8 (32mil)	28×28 (1.102×1.102)	30.6×30.6 (1.204×1.204)	31.9×31.9 (1.256×1.256)	Long Lead
FPQ-144-0.65-01A	144	0.65 (26mil)	28×28 (1.102×1.102)	30.3×30.3 (1.193×1.193)	31.2×31.2 (1.228×1.228)	Short Lead
FPQ-144-0.65-02A	144	0.65 (26mil)	28×28 (1.102×1.102)	30.9×30.9 (1.216×1.216)	31.9×31.9 (1.256×1.256)	Long Lead
FPQ-160-0.65-02A	160	0.65 (26mil)	28×28 (1.102×1.102)	30.6×30.6 (1.204×1.204)	32×32 (1.259×1.259)	Long Lead
FPQ-160-0.65-04A	160	0.65 (26mil)	28×28 (1.102×1.102)	30.5×30.5 (1.200×1.200)	32×32 (1.259×1.259)	Long Lead
FPQ-160-0.65-09A	160	0.65 (26mil)	28×28 (1.102×1.102)	30.5×30.5 (1.200×1.200)	32×32 (1.259×1.259)	Long Lead
FPQ-160-0.65-10	160	0.65 (26mil)	28×28 (1.102×1.102)	29.6×29.6 (1.165×1.165)	31.2×31.2 (1.228×1.228)	Short Lead
FPQ-208-0.5-06	208	0.5 (19.6mil)	28×28 (1.102×1.102)	29.8×29.8 (1.172×1.172)	30.6×30.6 (1.204×1.204)	Lead Guide
FPQ-208-0.5-09	208	0.5 (19.6mil)	28.25×28.25 (1.111×1.111)	29.6×29.6 (1.165×1.165)	30.6×30.6 (1.204×1.204)	Mold Guide
FPQ-304-0.5-04	304	0.5 (19.6mil)	40×40 (1.574×1.574)	41.6×41.6 (1.637×1.637)	42.6×42.6 (1.677×1.677)	Mold Guide

Unit: mm (in.)

PART NO.	PIN COUNT	PITCH	APPLICABLE IC DIMENSIONS (REF.)			REMARKS
			A	B	C	
FPQ-88-0.8-01A	88	0.8 (32mil)	20×20 (0.787×0.787)	22.2×22.2 (0.874×0.874)	25.6×25.6 (1.007×1.007)	
FPQ-100-0.5-06A	100	0.5 (19.6mil)	14×14 (0.551×0.551)	16.1×16.1 (0.633×0.633)	17.2×17.2 (0.236×0.236)	
FPQ-100-0.65-10D	100	0.65 (26mil)	20×14 (0.787×0.551)	16.4×22.4 (0.645×0.881)	25×19 (0.984×0.748)	
FPQ-112-0.65-01	112	0.65 (26mil)	20×20 (0.787×0.787)	22×22 (0.866×0.866)	23.2×23.2 (0.913×0.913)	
FPQ-120-0.8-02	120	0.8 (32mil)	28×28 (1.102×1.102)	30.4×30.4 (1.196×1.196)	32×32 (1.259×1.259)	Two pieces
FPQ-124-0.8-01	124	0.8 (32mil)	28×28 (1.102×1.102)	30.5×30.5 (1.200×1.200)	31.2×31.2 (1.228×1.228)	
FPQ-128-0.5-01A	128	0.5 (19.6mil)	20×14 (0.787×0.551)	22.3×16.3 (0.878×0.642)	23.6×17.6 (0.929×0.693)	Mold Gulid
FPQ-128-0.5-03A	128	0.5 (19.6mil)	20×14 (0.787×0.551)	22.3×16.3 (0.878×0.642)	23.2×17.2 (0.913×0.677)	Mold Gulid
FPQ-120(128)-0.5-03A	120	0.5 (19.6mil)				
FPQ-128-0.8-02A	128	0.8 (32mil)	28×28 (1.102×1.102)	30.6×30.6 (1.204×1.204)	33.2×33.2 (1.307×1.307)	
FPQ-132-0.635-07C	132	0.635 (25mil)	22.15×22.15 (0.872×0.872)	26.45×26.45 (1.041×1.041)	27.75×27.75 (1.092×1.092)	CQUAD
FPQ-148-0.65-02	148	0.65 (26mil)	28×28 (1.102×1.102)	30.5×30.5 (1.200×1.200)	31.2×31.2 (1.228×1.228)	
FPQ-168-0.65-02	168	0.65 (26mil)	28×28 (1.102×1.102)	30×30 (1.181×1.181)	31.2×31.2 (1.228×1.228)	
FPQ-208-0.5-02	208	0.5 (19.6mil)	28×28 (1.102×1.102)	29.6×29.6 (1.165×1.165)	31.3×31.3 (1.232×1.232)	Long Lead
FPQ-240-0.5-02	240	0.5 (19.6mil)	31.64×31.64 (1.245×1.245)	33.6×33.6 (1.322×1.322)	34.6×34.6 (1.362×1.362)	MQUAD
FPQ-240-0.5-03	240	0.5 (19.6mil)	32×32 (1.102×1.102)	33.6×33.6 (1.322×1.322)	34.6×34.6 (1.362×1.362)	PQFP
FPQ-240-0.5-04	240	0.5 (19.6mil)	32×32 (1.102×1.102)	33.9×33.9 (1.362×1.362)	34.6×34.6 (1.362×1.362)	
FPQ-240-0.5-05	240	0.5 (19.6mil)	31.04×31.04 (1.222×1.222)	33.9×33.9 (1.362×1.362)	34.6×34.6 (1.362×1.362)	
FPQ-304-0.5-03	304	0.5 (19.6mil)	40×40 (1.574×1.574)	41.6×41.6 (1.637×1.637)	42.6×42.6 (1.677×1.677)	MQUAD
FPQ-304-0.5-05	304	0.5 (19.6mil)	40×40 (1.574×1.574)	41.6×41.6 (1.637×1.637)	42.6×42.6 (1.677×1.677)	CQFP
FPQ-304-0.5-07	304	0.5 (19.6mil)				

Applicable IC/QFP • TQFP • MQFP • CQFP

CLAM SHELL TYPE SOCKET

TQFP (2.0 mm Forming)

Unit: mm (in)

PART NO.	PIN COUNT	PITCH	APPLICABLE IC DIMENSIONS (REF.)			REMARKS
			A	B	C	
FPQ-32-0.8-01	32	0.8 (32mil)	7×7 (0.275×0.275)	8×8 (0.315×0.315)	9×9 (0.354×0.354)	with Floating
FPQ-44-0.8-19	44	0.8 (32mil)	10×10 (0.394×0.394)	11×11 (0.433×0.433)	12×12 (0.472×0.472)	with Floating
FPQ-44-1.0-04D	44	1.0 (39mil)	14×14 (0.551×0.551)	15×15 (0.590×0.590)	16×16 (0.630×0.630)	
FPQ-48-0.5-06	48	0.5 (19.6mil)	7×7 (0.275×0.275)	8×8 (0.315×0.315)	9×9 (0.354×0.354)	with Floating
FPQ-64-0.5-06	64	0.5 (19.6mil)	10×10 (0.394×0.394)	11×11 (0.433×0.433)	12×12 (0.472×0.472)	with Floating
FPQ-72-0.5-01	72	0.5 (19.6mil)	10×10 (0.394×0.394)	11×11 (0.433×0.433)	12×12 (0.472×0.472)	with Floating
FPQ-80-0.5-04	80	0.5 (19.6mil)	12×12 (0.472×0.472)	13×13 (0.512×0.512)	14×14 (0.551×0.551)	with Floating
FPQ-80-0.5-07	80	0.5 (19.6mil)	12.4×12.4 (0.488×0.488)	13.2×13.2 (0.519×0.519)	14×14 (0.551×0.551)	with Floating
FPQ-80-0.65-09A	80	0.65 (26mil)				with Floating
FPQ-100-0.5-10A	100	0.5 (19.6mil)	14×14 (0.551×0.551)	15×15 (0.590×0.590)	16×16 (0.630×0.630)	with Floating
FPQ-100-0.5-14	100	0.5 (19.6mil)				Floating second cover
FPQ-120(128)-0.5-05	120	0.5 (19.6mil)	16.5×16.5 (0.650)	17×17 (0.669)	18×18 (0.709)	with Floating
FPQ-128-0.5-08	128	0.5 (19.6mil)	14.4×20.4 (0.566×0.803)	15.1×21.1 (0.594×0.830)	16×22 (0.630×0.866)	with Floating
FPQ-144-0.5-03	144	0.5 (19.6mil)	20×20 (0.887×0.787)	21×21 (0.827×0.827)	22×22 (0.806×0.806)	Floating second cover
FPQ-208-0.5-10	208	0.5 (19.6mil)	28×28 (1.102×1.102)	29×29 (1.142×1.142)	30×30 (1.181×1.181)	Floating second cover

FINE PITCH QFP (0.4mm Pitch)

Unit: mm (in)

PART NO.	PIN COUNT	PITCH	APPLICABLE IC DIMENSIONS (REF.)			REMARKS
			A	B	C	
FPQ-80-0.4-01	80	0.4 (15.7mil)	10×10 (0.394×0.394)	11×11 (0.433×0.433)	12×12 (0.472×0.472)	Floating second cover
FPQ-120(128)-0.4-01	120	0.4 (15.7mil)	14×14 (0.551×0.551)	15×15 (0.590×0.590)	16×16 (0.629×0.629)	Floating pedestal
FPQ-120(128)-0.4-02	120	0.4 (15.7mil)	13.94×13.94 (0.545×0.545)	15×15 (0.590×0.590)	16×16 (0.629×0.629)	Floating second cover
FPQ-128-0.4-02	128	0.4 (15.7mil)	max 14.5×14.5 (0.570×0.570)	15×15 (0.590×0.590)	16×16 (0.629×0.629)	Floating pedestal
FPQ-144-0.4-01	144	0.4 (15.7mil)	16×16 (0.629×0.629)	17×17 (0.669×0.669)	18×18 (0.708×0.708)	Floating second cover
FPQ-176(184)-0.4-01	176	0.4 (15.7mil)	20×20 (0.787×0.787)	21×21 (0.826×0.826)	22×22 (0.866×0.866)	Floating pedestal
FPQ-184-0.4-01	184	0.4 (15.7mil)	20×20 (0.787×0.787)	21×21 (0.826×0.826)	22×22 (0.866×0.866)	Floating pedestal
FPQ-216-0.4-03	216	0.4 (15.7mil)	24×24 (0.984×0.984)	25×25 (0.984×0.984)	26×26 (1.024×1.024)	Floating second cover
FPQ-256-0.4-02	256	0.4 (15.7mil)	28×28 (1.102×1.102)	29.6×29.6 (1.165×1.165)	30.6×20.6 (1.024×1.024)	Floating pedestal Short Lead
FPQ-256-0.4-03	256	0.4 (15.7mil)	28×28 (1.102×1.102)	29.4×29.4 (1.158×1.158)	31.2×31.2 (1.228×1.228)	Floating pedestal Long Lead
FPQ-376-0.4-02	376	0.4 (15.7mil)	40×40 (1.675×1.675)	41.6×41.6 (1.638×1.638)	42.6×42.6 (1.677×1.677)	Floating second cover